

Business Process Improvement

Let's Practice using Enterprise Architect

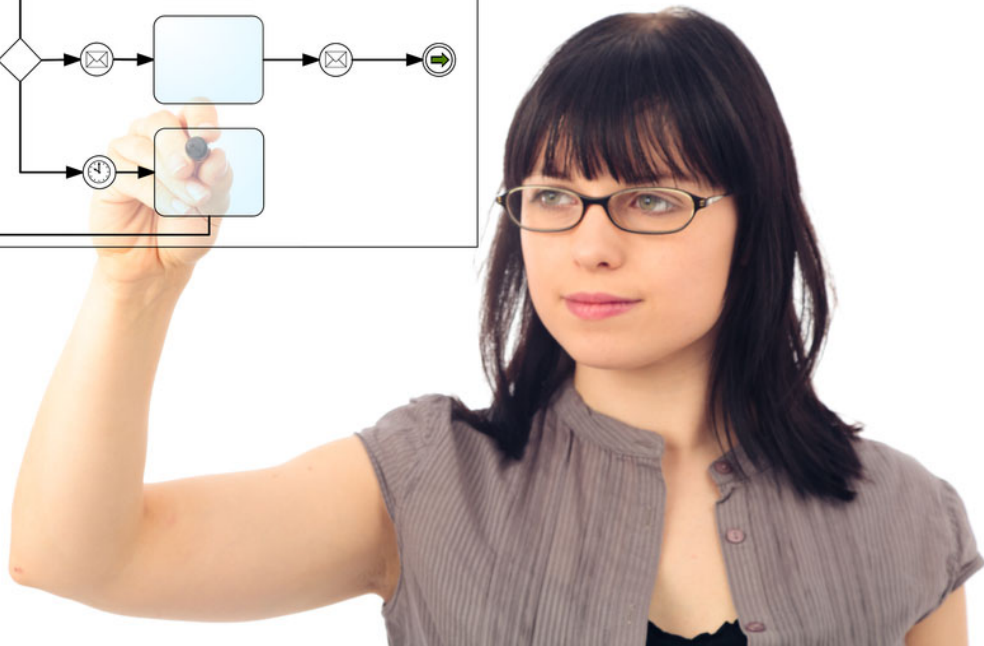
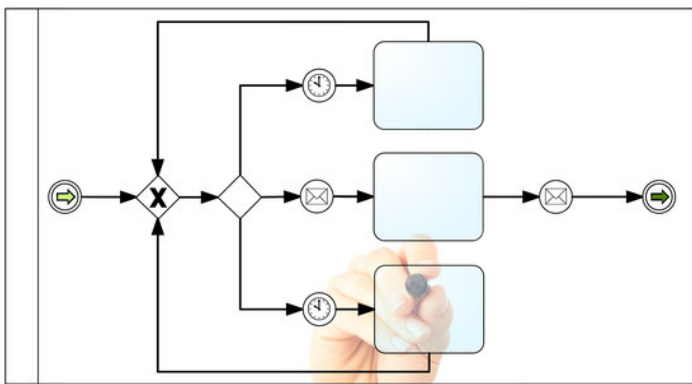
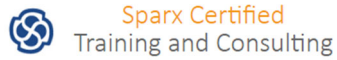

A practicing Process Analysts digital Courseware for mastering Business Process Improvement
Leveraging best practice techniques from APQC®, BABoK®, and BPMN®

Ramsay Millar, Enterprise Business Analyst and Mentor

Digital Copyright License Agreement

The Digital Learning Content provided herein is copyrighted and licensed for your personal learning and skills enhancement purposes only. The copyright license granted to individuals by INTEGRATE iT Inc. requires the digital content provided is for your individual use and may not be resold or distributed to others without permission.

Contact us at contact.us@IN2GRATEiT.com for rights requests, customized editions, and bulk orders.

Business Process Improvement – Let’s Practice using Enterprise Architect

Copyright© 2020 Ramsay Millar, INTEGRATE IT INC.

All rights reserved. This digital publication is protected by copyright, and permission must be obtained from the publisher prior to any reproduction, storage in a retrieval system, or transmission in any form or by any means, electronic. Mechanical, photocopying, recording or likewise.

Business Process Improvement

Let's Practice using Enterprise Architect

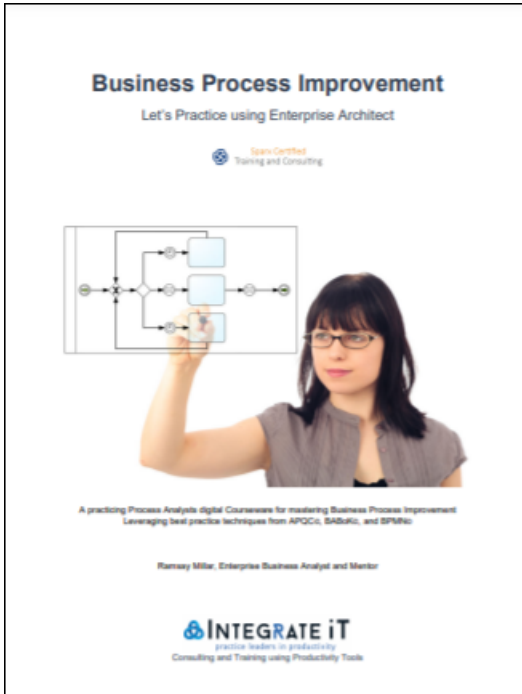

2 days - Mentored and written by experienced practitioners and Sparx Systems Certified Consultants

This focused hands-on course reveals the importance of leveraging APQC®, BABOK® and ArchiMate® methods and techniques. Learn directly from your assigned practitioner and you'll receive you provided Digital Let's Practice eCourse, Case Study, and Enterprise Architecture Repository to improve productivity and rapid adoption. This course contains 30% theory and 70% hands-on Let's Practice workshops that apply the theory to practice.

Not sure where to start with Business Process Improvement using BPMN 2.0? This intensive "hands-on" Workshop reveals the importance of developing Business Process modeling skills and techniques using Enterprise Architect. Work directly with a practice leader using Let's practice Course Workshops and Case Studies.

Establishing consistent readable process models is essential to any enterprise architecture, portfolio management, business analysis, requirements, and process improvement activity. The industry standard modeling language and notation managed by the Object Management Group (OMG), BPMN 2.0, consists of many visual elements and corresponding rules used for representing a variety of business processes

notations and techniques. You'll practice how to apply the BPMN modeling using provided rapid start patterns and stencils to help you ensure successful adoption BPMN 2.0 at your organization.

Discover surprising ways to improve productivity, methods, and techniques. Save time under the watchful eye of a practice leader with over 20 years of in-depth experience consulting and mentoring teams to develop process improvement initiatives. Master Enterprise Architect save time by learning methods and techniques used by leading industry experts and advanced business analysts.

Course Objectives

- Leverage the provided fully configured Enterprise Architecture Repository to reduce the learning curve
- Interact with reuse content to understand traceability and impacts
- Practice and Reuse APQC, BPMN Business Process Improvement Patterns and Techniques
- Become confident in your understanding and practices when using Sparx Enterprise Architect
- Learn by doing Let's Practice Workshop using the provided process improvement case study
- Practice Stakeholder Analysis
- Practice modeling Value Chain
- Practice modeling Process Collaboration
- Practice creating a Process Scope to reduce time improving BPMN process models
- Practice Concept Modeling and writing Business Rules
- Practice Developing Process Requirements
- Practice Modeling based upon "Model BPMN Quick and Easy by Bruce Silver
- Generate Business Process Improvement models to the Web or SharePoint



Consulting and Training using Productivity Tools

Business Process Improvement

Let's Practice using Enterprise Architect



What you'll Receive

Experience the most comprehensive Training available when you schedule your next event from INTEGRATE IT. Learn from highly experienced consultant trainers who reveal proven industry best practices and prepares you or your team to become highly skilled and confident in your use of Enterprise Architect. Please contact me immediately if you have any problems with your installation or course readiness. Ramsay.millar@in2grateit.com or call 1 (541) 645-0016



Ramsay Millar, Mentor
Sparx Certified Consultant and Trainer

Consultant, Trainer, TOGAF and Sparx Systems Certified Enterprise Architect Ramsay Millar has delivered over 1,100 business and technology modeling project assignments and trained over 4,000 business architects, business analysts, enterprise architects, agile project managers, solution architects and software engineers since 2001. The professionals Ramsay has mentored appreciate his common sense, wide industry skills, and the direct experience he brings to the show. LinkIn <https://www.linkedin.com/in/ramsay-millar-616b915/>



Use a Browser to access the supplied **Practice Lead eBook** on Device 1 (dual screen, PC, or Tablet) to view, search, print, and make notes on your personal eBook. The Let's Practice hands-on eBook contains practical steps to follow and deliver your next project using Enterprise Architect. Your eBook is linked to the **EA Case Study**.



Download and install the supplied **EA Case study to your Desktop** on a Windows 10 (Enterprise Architect enabled PC). The **EA Case Study** and additional course resources contain everything you need to get started including reusable Repository, Project and Document Templates, Diagram Stencils, and real-world consulting Case Study examples.



Consulting and Training using Productivity Tools

Business Process Improvement

Let's Practice using Enterprise Architect



What You'll Practice

Our training leverages standards. What students will learn is how to apply lean standards using the Sparx Systems Enterprise Architect architecture repository that deliver value and reduce risk by modeling before building. Experience insights and techniques with a watchful eye of a highly skilled Archimate certified TOGAF® Architect, who is directly involved in many successful consulting engagements using lean standards, tools, and techniques. Build your team, tool skills, and techniques. You'll experience hands-on learning doing one iteration of the TOGAF® Architecture Development Method:

Getting Started

1. Course Introduction
2. Login to the Architecture Repository – Let's Practice!
3. Using your Let's Practice eBook – Let's Practice!
4. Configuring the Architecture Repository
5. Modeling Best Practices
6. Navigating the Enterprise Architect Ribbon – Let's Practice!
7. START – Searching the Repository – Let's Practice!
8. DESIGN – Packages, Diagrams, Elements – Let's Practice!
9. LAYOUT - Themes and Appearance – Let's Practice!
10. DEVELOP – Database Modeling
11. PUBLISH – Publish Documentation
12. SIMULATE – Business Process Simulation
13. SPECIALIZE - Microsoft Office Integration
14. CONSTRUCT – Kanban
15. EXECUTE - Code Execution
16. CONFIGURE – Security, Groups, Permissions
17. Deploy Enterprise Architect

Business Layer

1. Leveraging Reuse Knowledge & Patterns
2. Develop the Target Business Architecture – Let's Practice!
3. Stakeholder Analysis – Let's Practice!
4. Business Capability Assessment – Let's Practice!
5. Concept Model and Glossary Management – Let's Practice!
6. Value Stream View – Let's Practice!
7. Process Cooperation View - Let's Practice!
8. Process Scope View – Let's Practice!
9. Service Information Accountability View – Let's Practice!
10. Requirements Management – Let's Practice!
11. Capability Planning Roadmap – Let's Practice!
12. Resolve Impacts and Traceability – Let's Practice!
13. Formal Stakeholder Review
14. Generate the Business Process Improvement Document - Let's Practice!



Consulting and Training using Productivity Tools

Business Process Improvement

Let's Practice using Enterprise Architect



Business Process Improvement

1. Process Modeling Best Practice using BPMN
2. Process Modeling Method and Style
3. Cruise Lines Consulting example
4. Step 1 – Model Process Scope – Let's Practice!
5. Step 2 – Model Happy Path – Let's Practice!
6. Step 3 – Model Complexity – Let's Practice!
7. Step 4 – Determine Who does What – Let's Practice!
8. Step 5 – Model BPMN Final – Let's Practice!
9. Business Process Improvement
10. Business Rules – Let's Practice!
11. Data Requirements – Let's Practice!
12. Process Requirements and Traceability – Let's Practice!
13. Generate BPMN Web Documentation – Let's Practice!

Testimonials

- [Healthcare Transformation Case Study-Acceleration without sacrificing Quality](#)
- *"Congrats and we who have taken a Ramsay Millar class know his superior technical education skills. Content, delivery, and real-world practical application of what you learn is his hallmark. INTEGRATE IT Inc. is so fortunate to have such a professional on staff for so long. When you have Ramsay as a mentor and instructor, you are a student for life, and you resolve the toughest issues together. Thank you, Ramsay; I am so grateful to be a student of your work. I hope soon the world will see the value of your work and why it is the cornerstone of digital transformation "* – Patrick Simon, Beehive Consulting
- *"The Toolkits provided by INTEGRATE iT during the course saved our Fortune 10 Healthcare company many months of standards work and setup time, we began our critical project immediately after training. There isn't a week that goes by when I'm not using one of the productivity tools to help solve problems, speed things or make my team more productive."* - Fiona Lindberg, Business Architect – McKesson Health Systems
- *"Even though Enterprise Architect is an extremely powerful tool and more feature rich than all the competing products we have reviewed in our RFP, it is hard to apply it without proper mentorship delivered by Ramsay Millar."* – Marc Ginns, Chief Enterprise Architect, Duke Energy

Certifications

Our practitioners work closely with every student to personally ensure they fully grasp every lesson plan during the hands-on Let's Practice sessions and after the course to mentor your Archimate® and BiZBoK® Certification is achieved.



- Sparx Systems Enterprise Architect Certification
- Certificate of Education Credit Hours



Consulting and Training using Productivity Tools